

2/2-Way Globe Control Valve, Pneumatically Operated Cast Stainless Steel Body with Threaded Ports

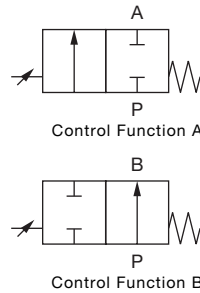

2712

DN 10 – 50



- ✓ Fully integrated in Burkert's Easy Process Control Systems
- ✓ New generation with interchangeable trims, all in stainless steel
- ✓ Integrated, cascade process controller with PID algorithm
- ✓ Automatic self-adjustment of basic parameters means autotune for the valve and for PID
- ✓ Quality certifications available

2712

Picture showing a complete Burkert System using Type 2712 with TOP Control 8630

Control valve 2712 consists of a globe valve body with pneumatic piston actuator. The trim is in the form of a parabolic plug/seat system. This results in a favourable characteristic for continuous variation of the flow as a function of the parabolic plug position. Type 2712 can be actuated by the Continuous TOP Control type 8630 or SIDE Control Type 1067 and 8635. TOP Control/SIDE Control thus forms a mechanical and functional unit with the pneumatic actuator as a complete control valve system. With this control valve system, every need in the continuous control of fluids can be solved.

Process Specification

Materials	
Body	Cast Stainless Steel 316 L (conform to 1.4409)
Actuator	PA
Sealing	<ul style="list-style-type: none"> • SS/SS • PTFE/SS
Process media (for gases and liquids)	<ul style="list-style-type: none"> • For neutral gases, water, alcohols, oils, fuels, hydraulic liquids, salt solutions, lyes, organic solvents, steam (10 bar/+180 °C)
Viscosity	Max. 600 mm ² /s
Packing gland	PTFE V-rings (silicone grease) with spring compensation PN 25 (body)
Nominal pressure	PN 25 (body)
Temperatures	
Fluid	-10°C... +180°C
Ambient	-10°C... +60°C
Control media	Instrument air class of 3 DIN ISO 8573-1
Pilot pressure	5.5... 7 bar
Threads	G 1/4 stainless steel (SS)
Flow direction	Below seat
Interchangeable seat	Different Kvs-values per port size
Valve characteristics	See flow-rate characteristics on page 2
Control ratio	Kvs/Kvo 50:1
Seatleakage IEC 534-4/EN 1349	Shut-off class IV for SS/SS Shut-off class VI for PTFE/SS
Port connections	
Threaded Port	G
	NPT
	Rc
	<ul style="list-style-type: none"> • DIN ISO 228 T1 • ASA B2.1 • ISO 7

Applications: Food & Beverage

- CIP / SIP; Steam
- Auxiliary Processes

Water Treatment

- Air Control
- Chemical Dosing

Cosmetics

- CIP / SIP; Steam

Textile

- Steam; Water; Air; Dyeing



Port size (tube) [mm]	Orifice DN (seat) [mm]			Actuator size [mm]	Kvs-value water			Weight with controller 8630 [kg]
	1	2	3		1	2	3	
10	-	8	10	F-80	-	2.0	2.7	2.9
15	8	10	15	F-80	2.1	3.1	4.3	2.9
20	10	15	20	F-80	3.2	5.2	7.1	3.0
25	15	20	25	F-80	5.3	7.2	12.0	3.6
32	20	25	32	G-100	8.0	13.0	17.8	6.4
40	25	32	40	G-100	13.6	20.2	23.8	7.0
50	32	40	50	H-125	21.0	24.6	37.0	10.8

2/2-Way Globe Control Valve, Pneumatically Operated Cast Stainless Steel Body with Threaded Ports

Flow curve and description

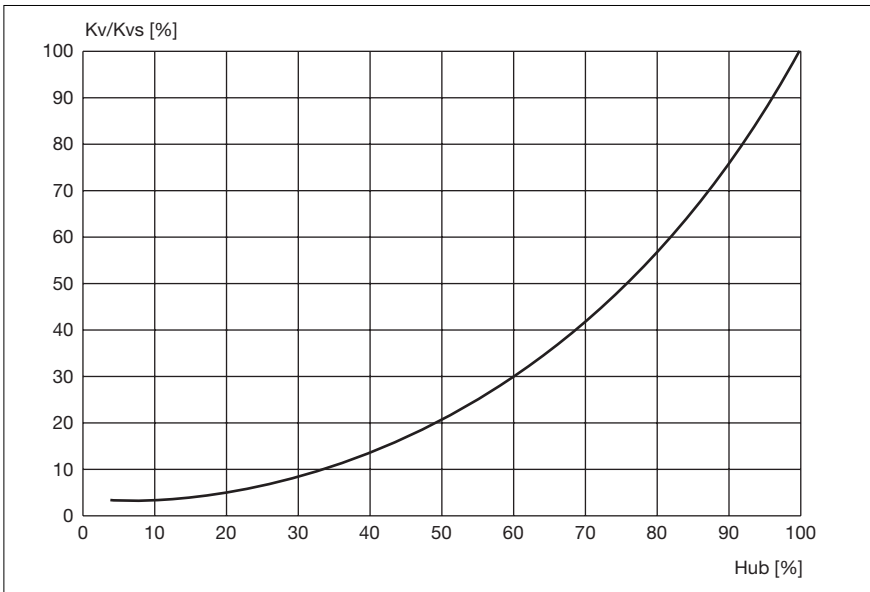

Remarks on the flow characteristic

- Equipercentile parabolic plug; linear plug can also be supplied
- Flow characteristic runs within DIN/IEC 534-2-4
- Theoretical control ratio $K_{vs}/K_{vo} = 50 : 1$ other control ratios can also be realized
- K_{vR} value at 5% of stroke for $DN > 10$ mm
 K_{vR} value at 10% of stroke for $DN \leq 10$ mm
(K_{vR} value = smallest K_v value at which the gradient tolerance to DIN/IEC 534-2-4 is still complied with)

Kv values [m3/h]

Port size (tube)		Orifice (seat)		Stroke [%]										
[mm]	[inch]	[mm]	[inch]	5	10	20	30	40	50	60	70	80	90	100
10	3/8"	8	1/4"	0.06	0.07	0.09	0.12	0.18	0.26	0.42	0.61	0.92	1.5	2.0
10	3/8"	10	3/8"	0.09	0.11	0.13	0.19	0.30	0.48	0.73	1.00	1.60	2.3	2.7
15	1/2"	8	1/4"	0.07	0.08	0.11	0.13	0.19	0.27	0.43	0.63	0.95	1.6	2.1
15	1/2"	10	3/8"	0.09	0.11	0.15	0.19	0.31	0.49	0.75	1.10	1.70	2.5	3.1
15	1/2"	15	1/2"	0.14	0.17	0.22	0.35	0.52	0.80	1.20	1.80	2.70	3.7	4.3
20	3/4"	10	3/8"	0.11	0.12	0.16	0.20	0.33	0.52	0.77	1.20	1.80	2.6	3.2
20	3/4"	15	1/2"	0.14	0.17	0.22	0.35	0.52	0.80	1.20	1.80	2.90	4.0	5.2
20	3/4"	20	3/4"	0.20	0.25	0.30	0.45	0.70	1.10	1.60	2.40	3.50	5.2	7.1
25	1"	15	1/2"	0.14	0.17	0.22	0.35	0.52	0.80	1.20	1.80	2.90	4.1	5.3
25	1"	20	3/4"	0.20	0.25	0.31	0.47	0.70	1.10	1.60	2.50	3.80	5.4	7.2
25	1"	25	1"	0.35	0.38	0.65	1.00	1.50	2.20	3.40	5.10	7.00	9.4	12.0
32	1 1/4"	20	3/4"	0.22	0.25	0.35	0.50	0.75	1.10	1.60	2.50	3.80	5.8	8.0
32	1 1/4"	25	1"	0.40	0.47	0.73	1.10	1.60	2.50	3.70	5.40	7.50	10.3	13.0
32	1 1/4"	32	1 1/4"	0.48	0.60	0.85	1.30	2.10	3.10	4.50	6.80	10.20	14.0	17.8
40	1 1/2"	25	1"	0.40	0.50	0.75	1.10	1.70	2.60	3.80	5.60	8.00	10.7	13.6
40	1 1/2"	32	1 1/4"	0.48	0.60	0.85	1.30	2.10	3.20	4.60	6.90	11.00	15.0	20.2
40	1 1/2"	40	1 1/2"	0.60	0.70	1.10	1.70	2.70	4.00	6.00	9.20	13.80	18.2	23.8
50	2"	32	1 1/4"	0.48	0.60	0.90	1.30	2.10	3.20	4.60	6.90	11.60	16.0	21.0
50	2"	40	1 1/2"	0.60	0.70	1.00	1.70	2.60	4.00	5.90	9.20	14.00	18.9	24.6
50	2"	50	2"	0.90	1.10	1.90	2.90	4.50	6.80	10.50	15.50	22.00	29.3	37.0

2/2-Way Globe Control Valve, Pneumatically Operated Cast Stainless Steel Body with Threaded Ports

Continuous Globe valve

2712

Ordering chart: Globe Valve Systems

Threaded Port G • DIN ISO 228 T1						Flow below seat		
Circuit Function	Port size (tube)		Orifice DN (seat)		Actuator size ø [mm]	Op. pressure ≤+180°C [bar]	Item-No. seal system* SS/SS	Item-No. seal system* PTFE/SS
	[mm]	[inch]	[mm]	[inch]				
A	10	3/8"	8	1/4"	F-80	16.0	146 670 P	146 956 S
	10	3/8"	10	3/8"	F-80	16.0	146 692 S	146 980 X
	15	1/2"	8	1/4"	F-80	16.0	145 856 V	146 968 E
	15	1/2"	10	3/8"	F-80	16.0	146 704 E	146 992 P
	15	1/2"	15	1/2"	F-80	16.0	146 732 Z	147 020 Y
	20	3/4"	10	3/8"	F-80	16.0	146 718 B	147 006 X
	20	3/4"	15	1/2"	F-80	16.0	146 746 F	147 034 J
	20	3/4"	20	3/4"	F-80	16.0	146 774 B	147 062 W
	25	1"	15	1/2"	F-80	16.0	146 760 R	147 048 G
	25	1"	20	3/4"	F-80	16.0	146 788 A	147 076 U
	25	1"	25	1"	F-80	16.0	146 814 L	147 102 U
	32	1 1/4"	20	3/4"	G-100	16.0	146 802 Z	147 090 X
	32	1 1/4"	25	1"	G-100	16.0	146 826 Q	147 116 R
	32	1 1/4"	32	1 1/4"	G-100	16.0	146 852 S	147 142 T
	40	1 1/2"	25	1"	G-100	16.0	146 838 U	147 128 V
	40	1 1/2"	32	1 1/4"	G-100	16.0	146 864 W	146 185 N
	40	1 1/2"	40	1 1/2"	G-100	16.0	146 892 K	147 181 K
	50	2"	32	1 1/4"	H-125	16.0	146 878 C	147 167 U
	50	2"	40	1 1/2"	H-125	16.0	146 906 Z	147 198 U
	50	2"	50	2"	H-125	16.0	146 919 V	147 212 Z
B	10	3/8"	8	1/4"	F-80	16.0	146 676 H	146 962 Y
	10	3/8"	10	3/8"	F-80	16.0	146 698 G	146 986 R
	15	1/2"	8	1/4"	F-80	16.0	146 686 U	146 974 U
	15	1/2"	10	3/8"	F-80	16.0	146 711 U	146 999 W
	15	1/2"	15	1/2"	F-80	16.0	146 739 G	147 027 K
	20	3/4"	10	3/8"	F-80	16.0	146 725 S	147 013 M
	20	3/4"	15	1/2"	F-80	16.0	146 753 E	147 041 Z
	20	3/4"	20	3/4"	F-80	16.0	146 781 T	147 069 D
	25	1"	15	1/2"	F-80	16.0	146 767 C	147 055 X
	25	1"	20	3/4"	F-80	16.0	146 795 Z	147 083 L
	25	1"	25	1"	F-80	16.0	146 819 Z	147 109 B
	32	1 1/4"	20	3/4"	G-100	16.0	146 808 F	147 096 R
	32	1 1/4"	25	1"	G-100	16.0	146 832 N	147 122 P
	32	1 1/4"	32	1 1/4"	G-100	16.0	146 858 G	147 148 H
	40	1 1/2"	25	1"	G-100	16.0	146 845 T	147 135 L
	40	1 1/2"	32	1 1/4"	G-100	16.0	146 871 V	147 160 H
	40	1 1/2"	40	1 1/2"	G-100	16.0	146 899 S	147 191 M
	50	2"	32	1 1/4"	H-125	16.0	146 885 L	147 174 T
	50	2"	40	1 1/2"	H-125	16.0	146 913 P	147 205 B
	50	2"	50	2"	H-125	16.0	146 925 K	147 219 G



Threaded Port NPT • ASA B2.1						Flow below seat		
Circuit Function	Port size (tube)		Orifice DN (seat)		Actuator size ø [mm]	Op. pressure ≤+180°C [bar]	Item-No. seal system* SS/SS	Item-No. seal system* PTFE/SS
	[mm]	[inch]	[mm]	[inch]				
A	10	3/8"	8	1/4"	F-80	16.0	146 671 C	146 957 T
	10	3/8"	10	3/8"	F-80	16.0	146 693 T	146 981 L
	15	1/2"	8	1/4"	F-80	16.0	146 682 Y	146 969 F
	15	1/2"	10	3/8"	F-80	16.0	146 705 F	146 993 Q
	15	1/2"	15	1/2"	F-80	16.0	146 733 S	147 021 M
	20	3/4"	10	3/8"	F-80	16.0	146 719 C	147 007 Y
	20	3/4"	15	1/2"	F-80	16.0	146 747 G	147 035 K
	20	3/4"	20	3/4"	F-80	16.0	146 775 C	147 063 X
	25	1"	15	1/2"	F-80	16.0	146 761 E	147 049 H
	25	1"	20	3/4"	F-80	16.0	146 789 B	147 077 V
	25	1"	25	1"	F-80	16.0	146 815 M	147 103 V
	32	1 1/4"	20	3/4"	G-100	16.0	146 803 S	147 091 L
	32	1 1/4"	25	1"	G-100	16.0	146 827 R	147 117 J
	32	1 1/4"	32	1 1/4"	G-100	16.0	146 853 T	147 143 U
	40	1 1/2"	25	1"	G-100	16.0	146 839 V	147 129 W
	40	1 1/2"	32	1 1/4"	G-100	16.0	146 865 X	147 154 X
	40	1 1/2"	40	1 1/2"	G-100	16.0	146 893 L	147 182 L
	50	2"	32	1 1/4"	H-125	16.0	146 879 D	147 168 D
	50	2"	40	1 1/2"	H-125	16.0	146 907 S	147 199 V
	50	2"	50	2"	H-125	16.0	146 920 S	147 213 S
B	10	3/8"	8	1/4"	F-80	16.0	146 677 A	146 963 Z
	10	3/8"	10	3/8"	F-80	16.0	146 699 H	146 987 J
	15	1/2"	8	1/4"	F-80	16.0	146 687 V	146 975 V
	15	1/2"	10	3/8"	F-80	16.0	146 712 V	147 000 D
	15	1/2"	15	1/2"	F-80	16.0	146 740 M	147 028 U
	20	3/4"	10	3/8"	F-80	16.0	146 726 T	147 014 N
	20	3/4"	15	1/2"	F-80	16.0	146 754 F	147 042 S
	20	3/4"	20	3/4"	F-80	16.0	146 782 U	147 070 A
	25	1"	15	1/2"	F-80	16.0	146 768 M	147 056 Y
	25	1"	20	3/4"	F-80	16.0	146 796 S	147 084 M
	25	1"	25	1"	F-80	16.0	146 820 W	147 110 X
	32	1 1/4"	20	3/4"	G-100	16.0	146 809 G	147 097 J
	32	1 1/4"	25	1"	G-100	16.0	146 833 P	147 123 Q
	32	1 1/4"	32	1 1/4"	G-100	16.0	146 859 H	147 149 A
	40	1 1/2"	25	1"	G-100	16.0	146 846 U	147 136 M
	40	1 1/2"	32	1 1/4"	G-100	16.0	146 872 W	147 161 W
	40	1 1/2"	40	1 1/2"	G-100	16.0	146 900 F	147 192 N
	50	2"	32	1 1/4"	H-125	16.0	146 886 M	147 175 U
	50	2"	40	1 1/2"	H-125	16.0	146 914 Q	147 206 C
	50	2"	50	2"	H-125	16.0	146 926 L	147 220 D



*seal system: SS/SS plug stainless steel / seat stainless steel
PTFE/SS plug PTFE / seat stainless steel

2/2-Way Globe Control Valve, Pneumatically Operated Cast Stainless Steel Body with Threaded Ports

2712

DTS 1000010999 EN Version: A Status: RL (released | freigegeben | validé) printed: 30.06.2006

Threaded Port Rc • ISO 7						Flow below seat		
Circuit Function	Port size (tube)		Orifice DN (seat)		Actuator size ø [mm]	Op. pressure ≤+180°C [bar]	Item-No. seal system* SS/SS	Item-No. seal system* PTFE/SS
	[mm]	[inch]	[mm]	[inch]				
A	10	3/8"	8	1/4"	F-80	16.0	148 413 U	148 494 W
	10	3/8"	10	3/8"	F-80	16.0	148 419 A	148 500 Q
	15	1/2"	8	1/4"	F-80	16.0	148 416 X	148 497 Z
	15	1/2"	10	3/8"	F-80	16.0	148 422 V	148 503 F
	15	1/2"	15	1/2"	F-80	16.0	148 431 W	148 511 W
	20	3/4"	10	3/8"	F-80	16.0	148 427 S	148 507 B
	20	3/4"	15	1/2"	F-80	16.0	148 435 S	148 515 S
	20	3/4"	20	3/4"	F-80	16.0	148 444 B	148 523 S
	25	1"	15	1/2"	F-80	16.0	148 439 E	148 519 E
	25	1"	20	3/4"	F-80	16.0	148 448 P	148 527 W
	25	1"	25	1"	F-80	16.0	148 456 F	148 535 W
	32	1 1/4"	20	3/4"	G-100	16.0	148 451 A	148 531 S
	32	1 1/4"	25	1"	G-100	16.0	148 460 P	148 539 A
	32	1 1/4"	32	1 1/4"	G-100	16.0	148 469 L	148 547 A
	40	1 1/2"	25	1"	G-100	16.0	148 464 F	148 543 E
	40	1 1/2"	32	1 1/4"	G-100	16.0	148 473 G	148 551 E
	40	1 1/2"	40	1 1/2"	G-100	16.0	148 482 S	148 559 N
	50	2"	32	1 1/4"	H-125	16.0	148 478 M	148 555 A
	50	2"	40	1 1/2"	H-125	16.0	148 486 W	148 563 A
	50	2"	50	2"	H-125	16.0	148 490 E	148 567 E
B	10	3/8"	8	1/4"	F-80	16.0	148 414 V	148 495 X
	10	3/8"	10	3/8"	F-80	16.0	148 420 F	148 501 D
	15	1/2"	8	1/4"	F-80	16.0	148 418 H	148 499 B
	15	1/2"	10	3/8"	F-80	16.0	148 424 X	148 505 H
	15	1/2"	15	1/2"	F-80	16.0	148 433 Y	148 513 Y
	20	3/4"	10	3/8"	F-80	16.0	148 429 C	148 509 M
	20	3/4"	15	1/2"	F-80	16.0	148 437 U	148 517 U
	20	3/4"	20	3/4"	F-80	16.0	148 446 D	148 525 U
	25	1"	15	1/2"	F-80	16.0	148 442 H	148 521 Y
	25	1"	20	3/4"	F-80	16.0	148 450 M	148 529 G
	25	1"	25	1"	F-80	16.0	148 458 R	148 537 Y
	32	1 1/4"	20	3/4"	G-100	16.0	148 454 D	148 533 U
	32	1 1/4"	25	1"	G-100	16.0	148 462 D	148 541 C
	32	1 1/4"	32	1 1/4"	G-100	16.0	148 471 E	148 549 L
	40	1 1/2"	25	1"	G-100	16.0	148 467 A	148 545 G
	40	1 1/2"	32	1 1/4"	G-100	16.0	148 475 A	148 553 G
	40	1 1/2"	40	1 1/2"	G-100	16.0	148 484 U	148 561 G
	50	2"	32	1 1/4"	H-125	16.0	148 480 C	148 557 C
	50	2"	40	1 1/2"	H-125	16.0	148 488 G	148 565 C
	50	2"	50	2"	H-125	16.0	148 493 V	148 569 Q



Dimensions [mm]

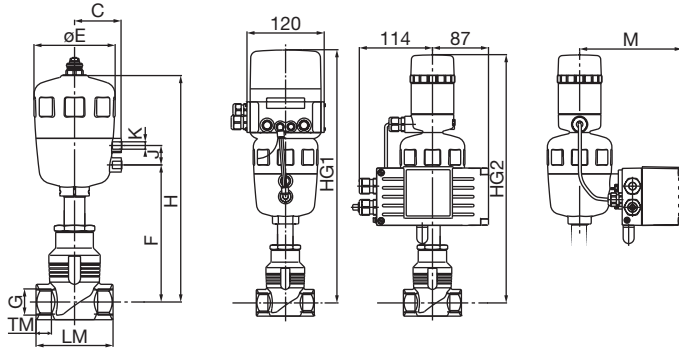

Port size	8630		1067		8635	
	HG ¹	HG ²	M	HG ²	M	
10	391	384	145	384	159	
15	391	384	145	384	159	
20	389	379	145	379	159	
25	389	382	145	382	159	
32	476	469	158	469	172	
40	481	474	158	474	172	
50	618	511	171	511	185	

All Actuators										G		NPT		Rc	
Port size	Act. size ø	C	E	F	H	K	J	HG	LM	G [inch]	TM	G [inch]	TM	G [inch]	TM
10	F-80	60	101	166	264	G 1/4	24	65	G 3/8	12.0	NPT 3/8	10.3	Rc 3/8	10.1	
15	F-80	60	101	166	264	G 1/4	24	65	G 1/2	14.0	NPT 1/2	13.7	Rc 1/2	13.2	
20	F-80	60	101	180	259	G 1/4	24	75	G 3/4	16.0	NPT 3/4	14.0	Rc 3/4	14.5	
25	F-80	60	101	164	262	G 1/4	24	90	G 1	18.0	NPT 1	16.8	Rc 1	16.8	
32	G-100	73	127	208	346	G 1/4	30	110	G 1 1/4	20.0	NPT 1 1/4	17.3	Rc 1 1/4	19.1	
40	G-100	73	127	213	351	G 1/4	30	120	G 1 1/2	22.0	NPT 1 1/2	17.3	Rc 1 1/2	19.1	
50	H-125	86	153	225	388	G 1/4	30	150	G 2	24.0	NPT 2	17.6	Rc 2	23.4	

Further Process Connections are:

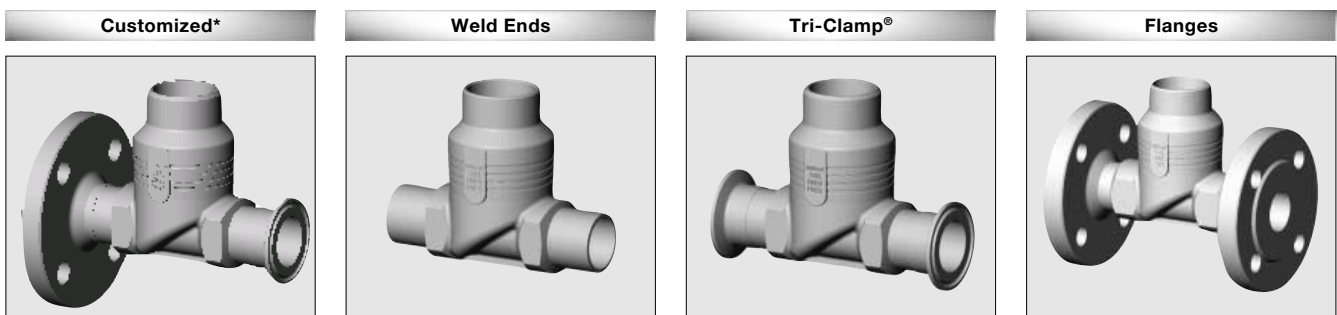

* e.g. one side with flange, other side Tri-Clamp®

2/2-Way Globe Control Valve, Pneumatically Operated Cast Stainless Steel Body with Threaded Ports

Valve Actuation System: TOP Control

Type: 8630

TOP Control Continuous type 8630 forms a mechanical and functional unit with the pneumatic actuator. Main functional groups of the TOP Control continuous are:

- Positioner and process controller in one device, integrated PID
- Position measuring system for continuous feedback of the actual position of the pneumatic actuator and the valve
- Microprocessor controlled electronics for signal processing, setpoint/process value comparison
- Pneumatic positioning system for single and double-acting actuators whose integrated pilot valves are driven by pulse-width modulation

TOP Control continuous can be used in a variety of different applications in fluid control solutions.



Valve Actuation System: SIDE Control 3-wire

Type: 1067

SIDE Control type 1067 is a 3-wire process controller and positioner composed of the main functional groups position measuring system, electropneumatic actuator system and microprocessor electronics.

Main functional groups of the SIDE Control continuous are:

- Positioner and process controller in one device, integrated PID
- Position measuring system for continuous feedback of the actual position of the pneumatic actuator and the valve
- Microprocessor controlled electronics for signal processing, setpoint/process value comparison
- Pneumatic positioning system for single and double-acting actuators whose integrated pilot valves are driven by pulse-width modulation



Valve Actuation System: SIDE Control 2-wire

Type: 8635

SIDE Control S type 8635S is a 2-wire electropneumatic process controller and positioner for pneumatically operated process valves. The input signal of 4 - 20 mA serves to transmit the set point signal and to supply the device with power at the same time.

As an alternative, communication can be effected via the HART protocol.

- The HART protocol is modulated onto the current signal using the FSK procedure (Frequency Shift Keying)
- Signal processing, control and drive of the internal positioning system are carried out by microprocessor controlled electronics
- The software function autotune implemented enables automatic adaptation of the positioner to the control valve used
- Parametrization and operation are performed comfortably via three keys and a display with plain text, or via the HART protocol (optional)
- To build up a decentralized control system, SIDE Control is equipped with a process controller with PID behaviour. In this case, a process control loop is superimposed on the positioning loop in a cascade structure
- The compact, robust design, the housing is suitable for use in chemical and process engineering



2/2-Way Globe Control Valve, Pneumatically Operated Cast Stainless Steel Body with Threaded Ports

Globe Valve Systems

A continuous globe valve system consists of a continuous globe valve type 2712 and a valve actuation system TOP Control type 8630 or SIDE Control type 1067 or 8635.

Burkert offers a wide range of valve actuation systems suitable for the new continuous globe valve.

Example for variations of continuous globe valve systems



Globe Valve



Valve Actuation



Complete Continuous Globe Valve Systems

2712
Globe Valve
with required
process connection

Valve Actuation
with all its needs
TOP Control or
SIDE Control

2712+8630
Globe Valve
TOP Control
system

2712+1067
Globe Valve
SIDE Control
system

2712+8635
Globe Valve
SIDE Control
system